



**PESS**  
Power Electronic System Solutions



# Quick Installation Guide

## UPS\_11 Open Frame Module

---

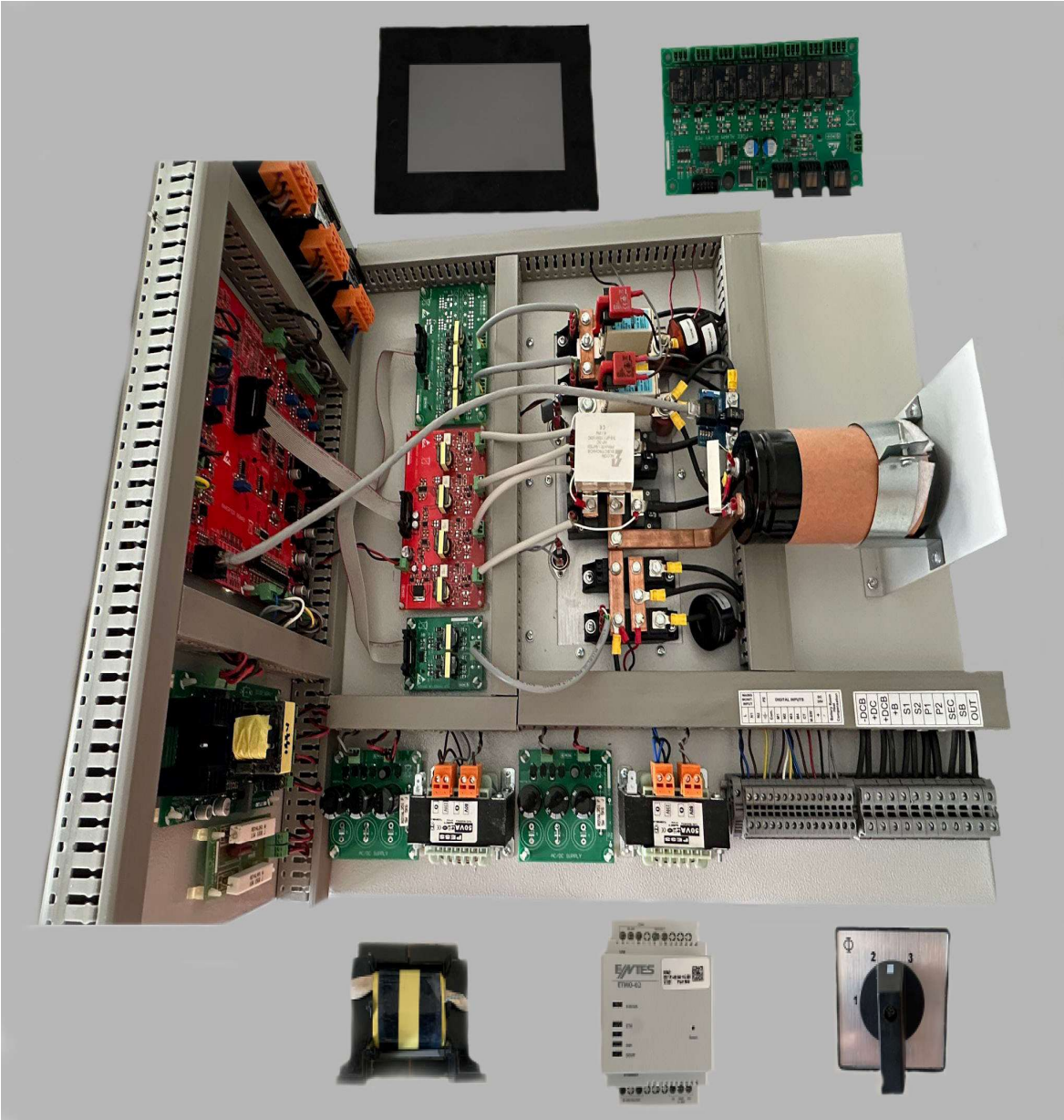

This sheet explains how to use UPS\_11 230VA /114VDC/230VAC 2KVA open frame power module. You can understand connection details of UPS\_11 power module to setup your own full cabinet UPS. Please don't hurry about to energize system, read and understand full details of wirings and be careful about first energizing and test of the system. As you see from the above picture; Open Frame module will come with external devices like TFT Panel, Relay Board, Output HF Inductor, Maintenance switch, TCP converter. Other requirements like power transformers, power cables, MCB/MCCB, outside cabinet etc. will be used from customer side. In every step during the build of your own system please use project drawings and this installation guide together.

# 1. High Power Terminals

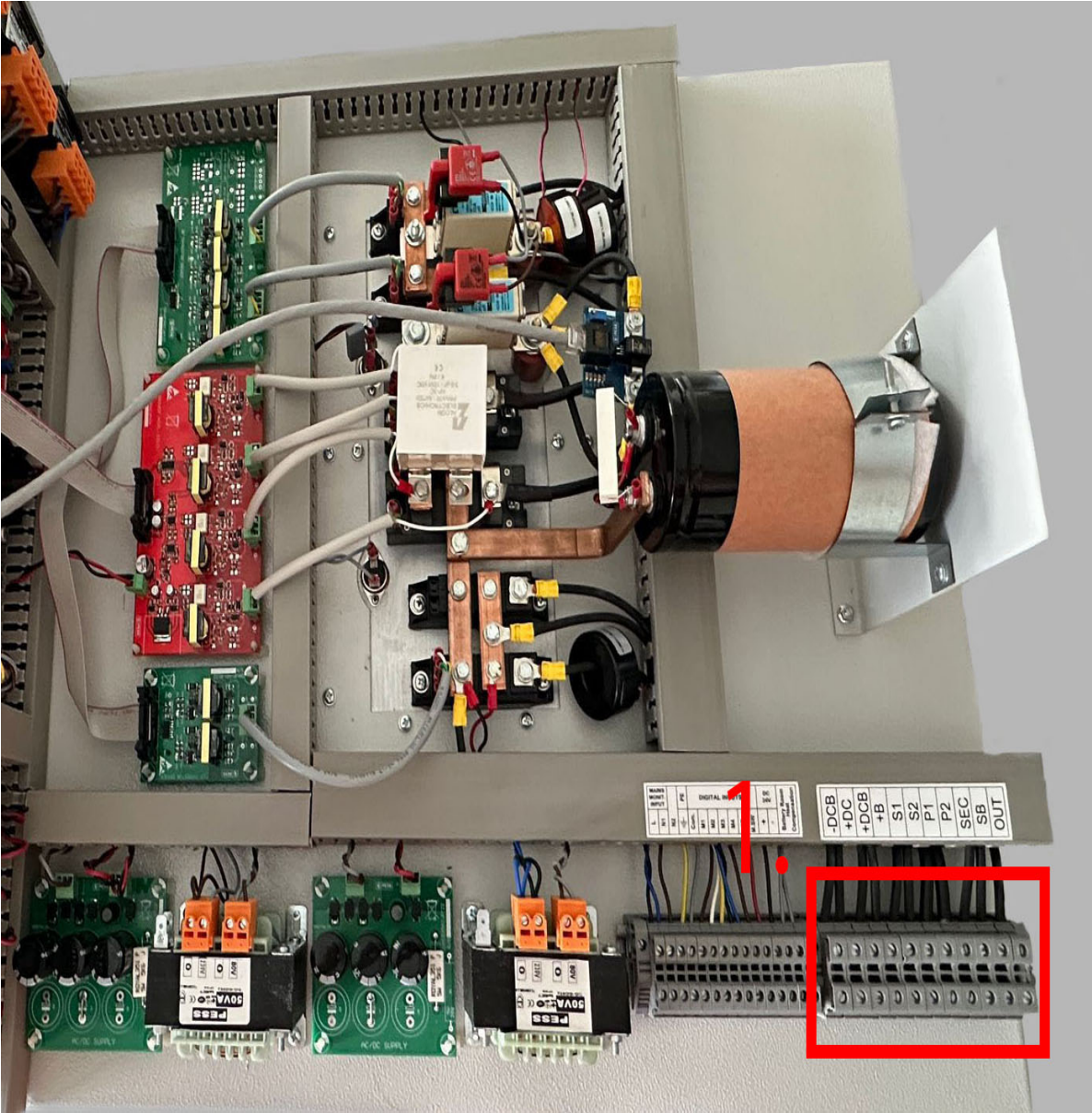

Figure 2. High power cable connection points (port 1)

As you see from Figure 2; all high power input/output cables have connection terminals . **S1,S2 phase sequence** has most importance for rectifier safe operating, if there is wrong connection rectifier thyristors will trigger as wrong and DC capacitor of system **may explode**. **This will cause to fail/burn** some PCB's and after that it will be very hard to return normal system operation. To understand your own transformer sequence is true or not, please apply "Rectifier Safe-Starting Procedure" step by step. Using an **oscilloscope** is important for these steps, please get an isolated scope for this purpose. **You have to use an isolation transformer** to supply your scope from your grid. If you apply "Rectifier Safe-Starting Procedure" step by step, there will be no problem and after the first build you will not need to apply same procedure.



## 2. Low Signal Connection Points

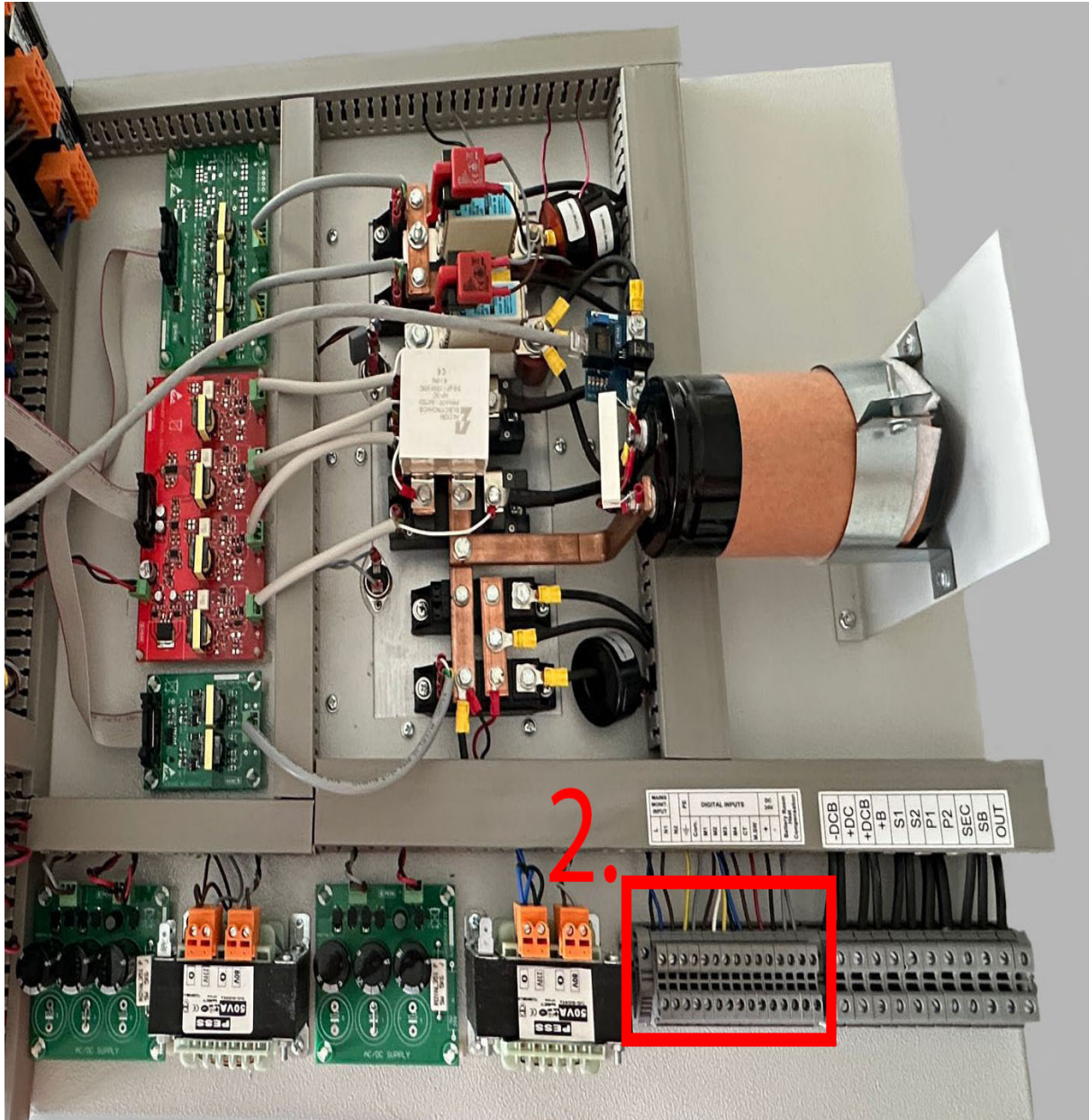
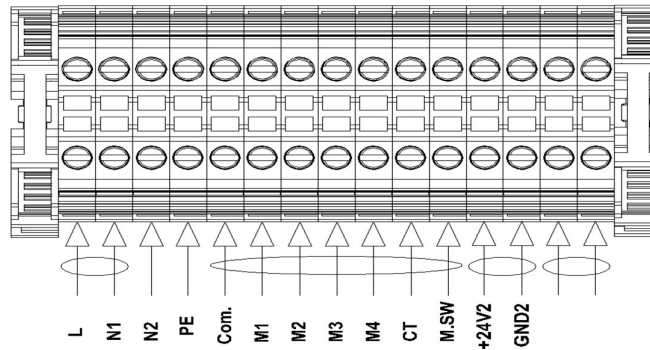

Figure 3. Low signal cable connection points (port 2)

Low signal cables consist of; primary ac feedback like L, N1 input voltages, auxiliary contacts of input MCB, battery fuse etc., heat compensation thermistor cable input from battery room, 24Vdc output for relay board power supply, case connection terminal etc. **L, N1 connection sequence** has most importance for rectifier safe operating, if there is wrong connection rectifier thyristors will trigger as wrong and DC capacitor of system **may explode**. **This will cause to fail/burn** some PCB's and after that it will be very hard to return normal system operation. To understand your own transformer sequence is true or not, pls apply "Rectifier Safe-Starting Procedure" step by step. **24Vdc (+) & (-) connection** also very important, if you connect as reverse to relay PCB, **Relay PCB will get damage and out of service**. This terminal is shown below as detailed.

MAINS MONIT. INPUT			PE	DIGITAL INPUTS							DC 24V		Battery Room Heat Compensation
L	N1	N2		Com.	M1	M2	M3	M4	CT	M.SW	+	-	



**Figure 4.** Low signal cable connection points (port 2)

**L, N1 Case:** These connections coming from input side of ups, customer grid connections coming here as feedback of control PCB's. So system L, N Case should be connected to here with **0,75mm<sup>2</sup> cables**. True sequence is so important that Main PCB saw these feedback and trigger thyristors with synchronized to this feedback. As you understand; L1,N1 sequence have to be be synchronized with transformer secondary S1,S2 signals. To trigger rectifier thyristors in a safe way, and to avoid -DC bus creating and **to avoid DC capacitor explosion**, please see "Rectifier Safe-Starting Procedure".

### 3. Rectifier Connection Procedure

Because rectifier input requires input breaker, varistor, input transformer as external from power module; and rectifier output includes inductor as external from power module; you are better to use power wiring diagram that you have as project pdf and Figure 5. as shown below. Please **don't connect "the second terminal of port 1 named as +DC"**, because it will be connected after success of "Rectifier Safe-Starting Procedure".

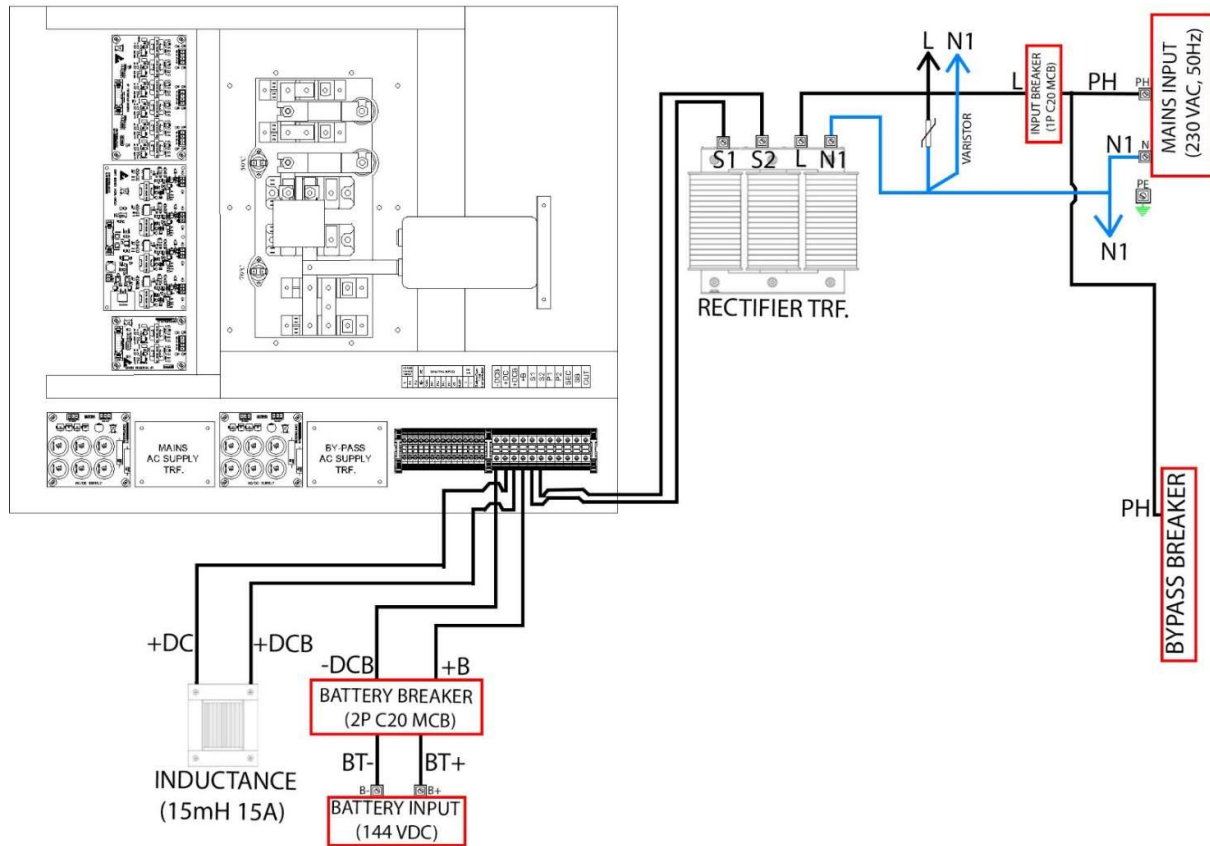

Figure 5. High power cable connections example block diagram of rectifier

#### 4. Rectifier Safe Starting Procedure

After you connected high power cables of port 1 like in Figure 5 and all low signal cables (port 2) to UPS\_11 module; you should apply below steps.

1. Disconnect the inductor return cable to terminal “+DCB” in terminal box (port 1). So, inductor will be removed rectifier out, rectifier out is not connected to DC bus capacitor, so there is no risk if thyristor trigger wrong, but we will see on scope screen and we can correct the connection.
2. Connect scope probe to between “+DC and -DCB” with a way. We will see thyristor triggered bus voltages on scope screen in every start-stop. Channel of scope should be adjusted as 100V/div, 5ms time div.
3. Don't turn on Battery MCB during these tests.
4. You can turn on Input MCB of rectifier, and rectifier will see low signal of L, N1 on TFT screen, and it will try to restart rectifier, so it will give thyristor triggers and you will see thyristor triggers on scope screen. You can repeat the restart with pressing rectifier ON/OFF button on the TFT panel.
5. If your thyristor triggers will be in Figure 6 and Figure 7, it means your connections and phase sequence are true. You can connect inductor to system with connecting second terminal of port 1 wiring. You can restart rectifier and you can measure DC bus voltages on the Battery MCB/Fuse as 163VDC floating. It means rectifier connections are true and you finished rectifier build in your cabinet.
6. If trigger signals on scope screen not shown in Figure 6, and Figure 7. You have to contact us on via WhatsApp and our service will help you to understand what is wrong.

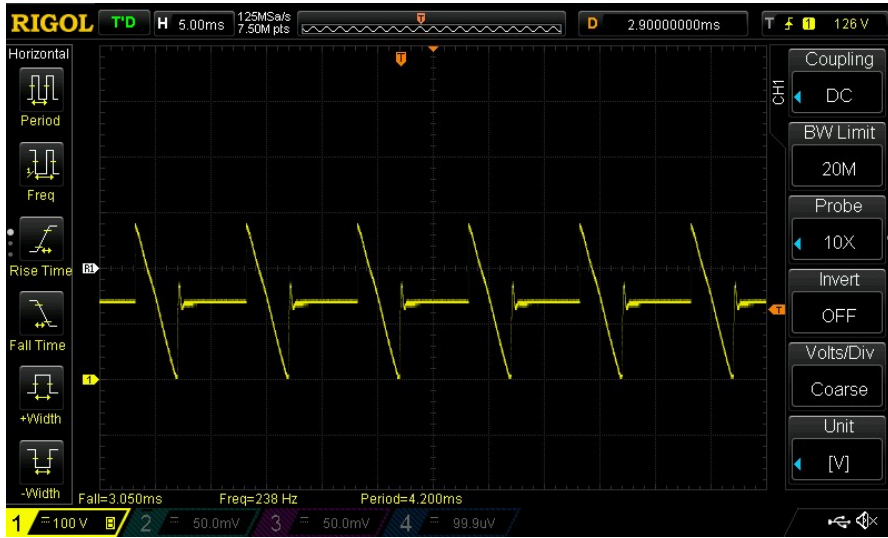

Figure 6. Single phase rectifier true thyristor bus voltage signal.



Figure 7. Single phase rectifier true thyristor bus voltage signal.



## 5. Inverter High Power Terminals

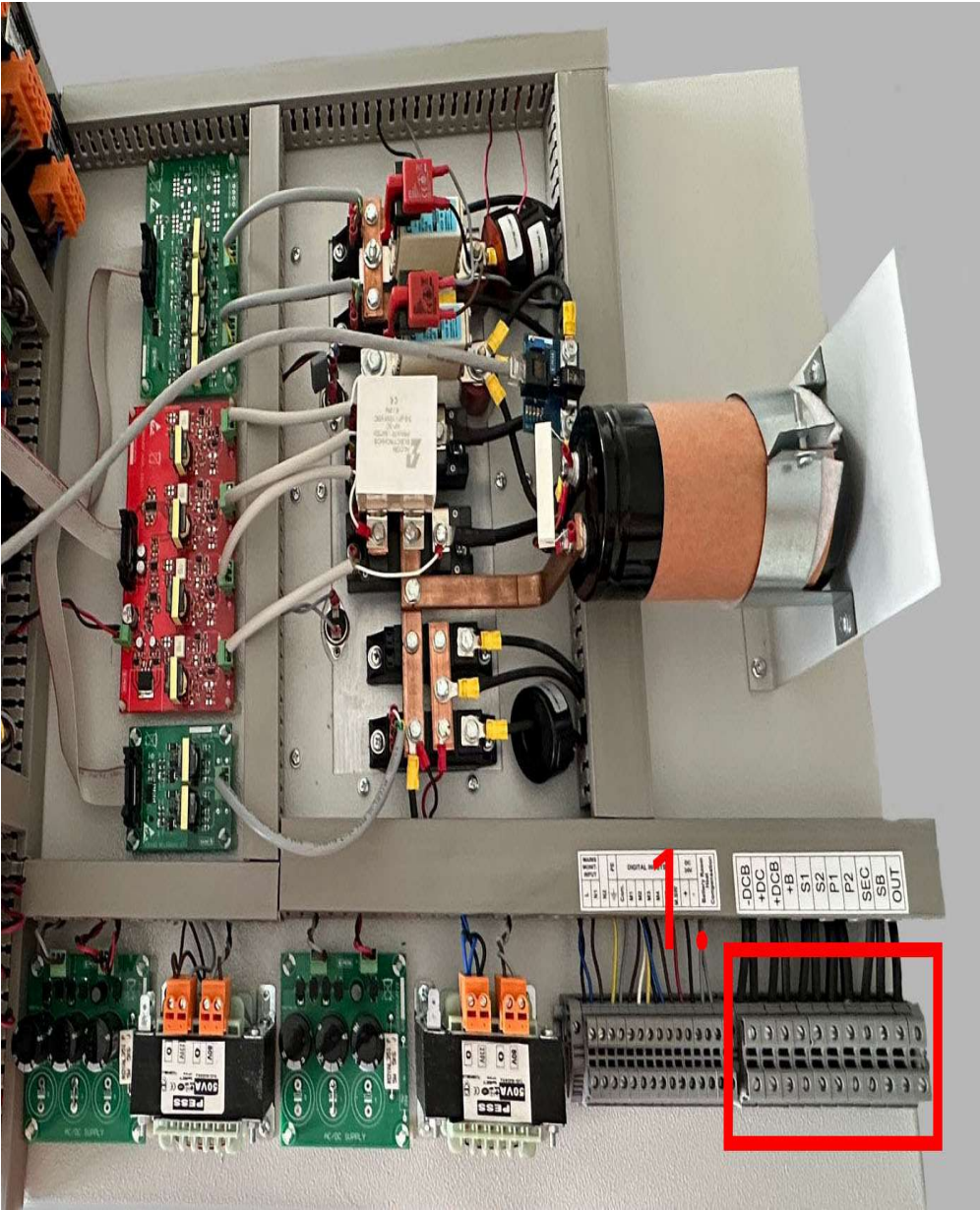
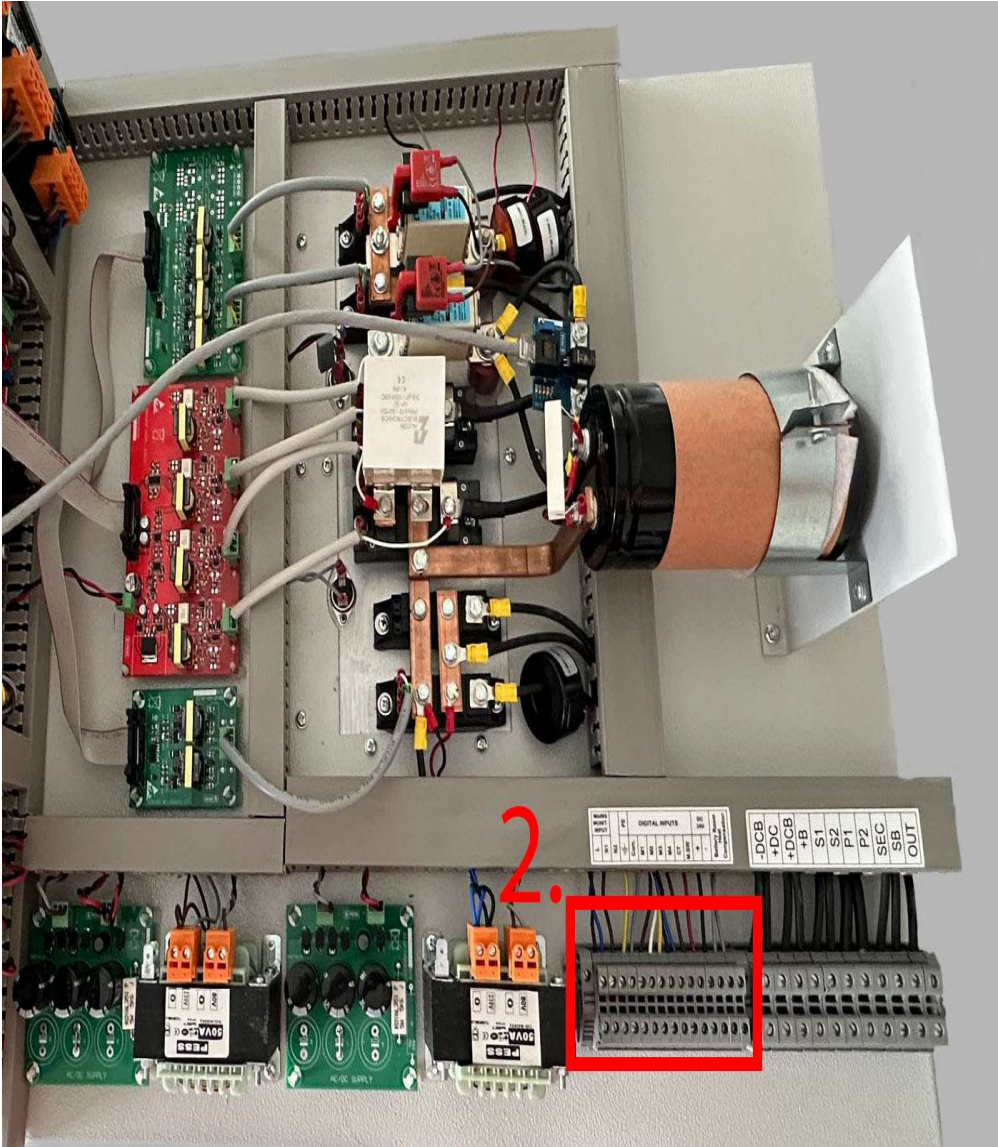

**Figure 8.** High power cable connection points of inverter (port 1)

As you see from Figure 8; all high power input/output cables have connection terminals for inverter side. High frequency (16khz) & high current switched signals named as P1&P2 is IGBT output signals that is going to inverter transformer primary. **P1&P2 phase sequence** has the most importance for inverter/bypass safe operating, if there is wrong connection inverter will work as full-asynchron to bypass line, but it assumes as synchron, so in any transfer to bypass/inverter it will create high overlap current and **IGBT may explode. This will cause to fail/burn** some PCB's and after that it will be very hard to return normal system operation. To understand your own transformer sequence is true or not, please apply "Inverter Safe-Starting Procedure" step by step. Using an voltmeter is important for these steps, please get an hand type voltmeter to measure synchron voltage between inverter/bypass. If you apply "Inverter Safe-Starting Procedure" step by step, there will be no problem and after the first build you will not need to apply same procedure.



## 6. Low Signal Connection Points of Inverter



**Figure 9.** Low signal cable connection points of inverter (port2)

Low signal cables are consist of; isolated neutral connection (N2) of bypass/output, auxiliary contacts of output and bypas mcb, auxiliary contacts of make before break maintenance switch (M.SW), core thermostat contact of output transformer (CT). You can see detailed picture of port2 in Figure 10 below. Please use **0.75mm<sup>2</sup> cable** to connect related cables. Connection of **N2 is so important** for system can read bypass/output voltages and synchronization feedback. If you connect N2 to wrong terminal of transformer secondary or other place, you will have problem with inverter synchronization. Please apply "Inverter Safe-Starting Procedure" step by step to avoid any problem.

MAINS MONIT. INPUT		PE	DIGITAL INPUTS							DC 24V		Battery Room Heat Compensation
L	N1		N2	Com.	M1	M2	M3	M4	CT	M.SW	+	

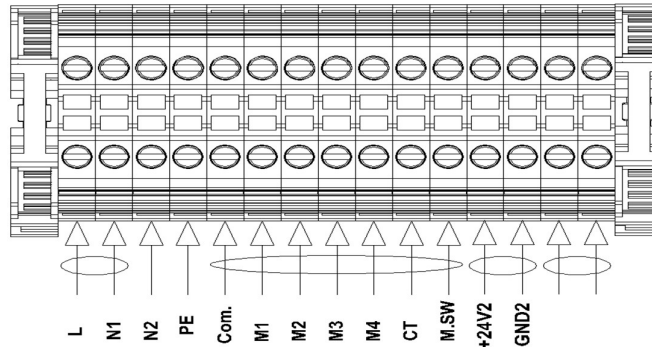

**Figure 10.** Low signal cable connection points of inverter side as detailed (port2)

## 7. Inverter Side Connection Procedure

Because inverter output requires inverter transformer, LC output filter, bypass transformer, make before break maintenance switch, output breaker, bypass breaker as external from power module; you are better to use power wiring diagram that you have as project pdf and Figure 11. as shown below.

High frequency (16khz) & high current switched signals named as P1&P2 is IGBT output signals that is going to inverter transformer primary. **This cables have to be twisted pair. Two pieces toroid** equally should be placed on the cable. This cable **should be short as possible as** for the best performance **between Port1 & inverter transformer.**

**-Please don't connect ups output MCB to the load at this step.**

-After you connected all cables, you can pass to "Inverter Safe-Starting Procedure".

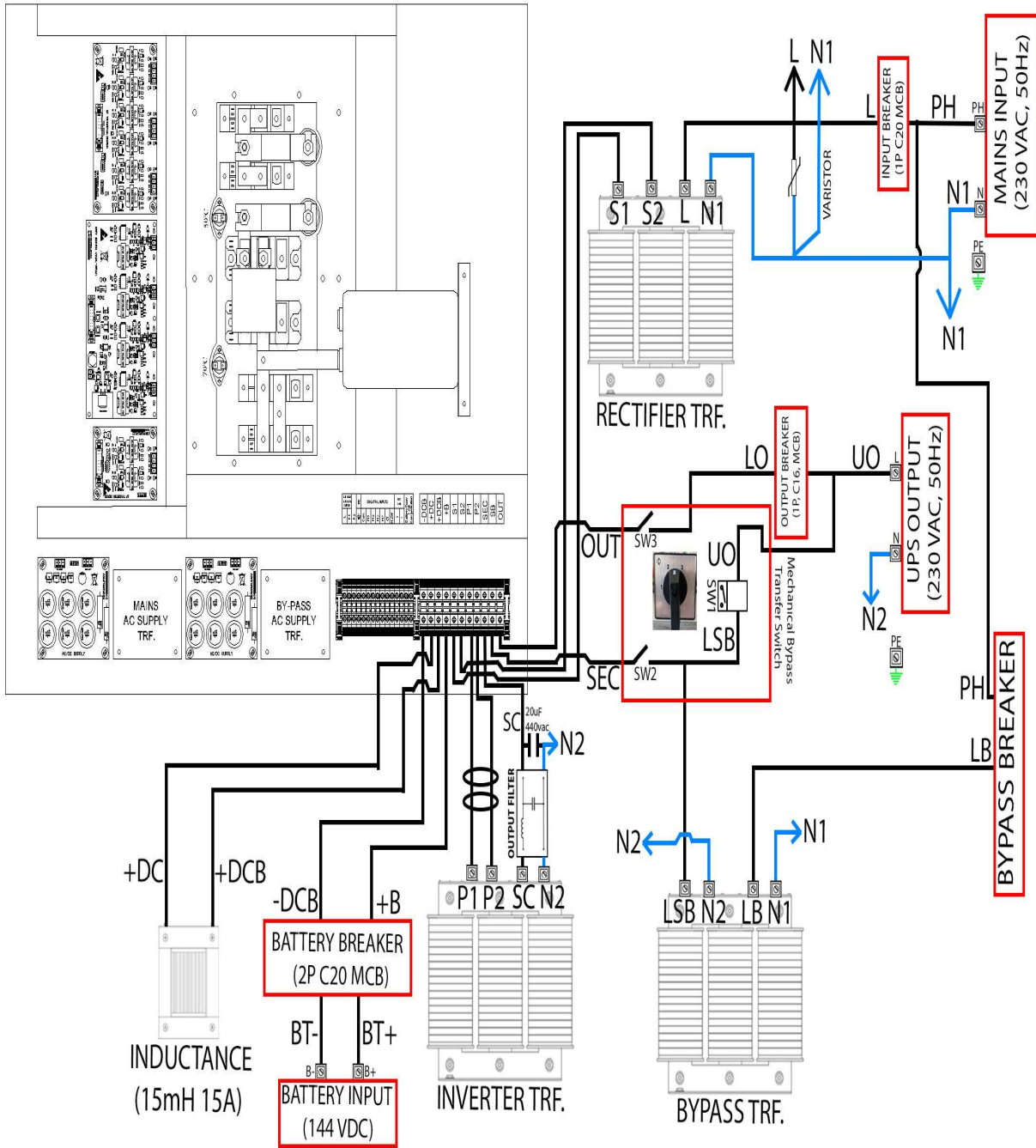
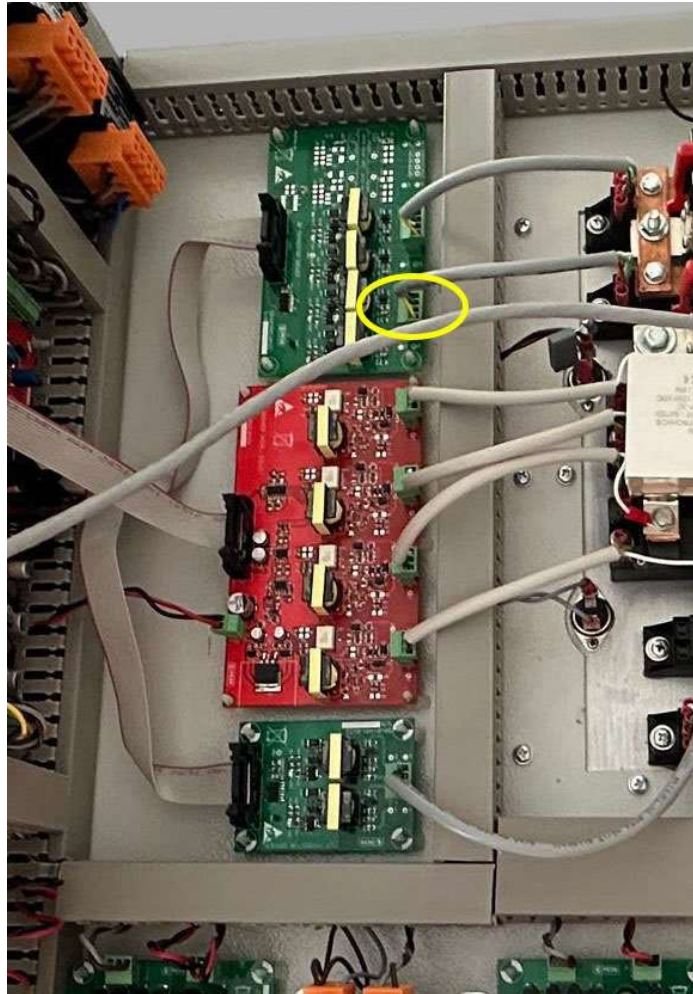

Figure 11. High power cable connections example block diagram of UPS



## 8. Inverter Safe Starting Procedure



**Figure 12.** Disconnecting inverter out thyristor to understand true synchronization

1. **Disconnect the inverter output thyristor triggering cable** from the driver board. It will help you to avoid transfer overlaps between inverter and bypass if your system connection has some faults about synchronization feedback.
2. Check your P1&P2 power cables going to inverter transformer P1&P2 labels. Check SEC, SB, OUT terminal cables going to bypass transformers and maintenance switch as true connection.
3. Turn on rectifier input MCB, check if DC bus voltage appear as soft started and 163V value. Check TFT screen monitor values are ok or not.
4. Turn on bypass MCB, check if bypass voltage appears on TFT screen, check monitor of bypass voltage values is ok or not. If ok, ups will drive bypass thyristor and you will see on bypass led on TFT.
5. Turn on inverter from TFT panel, and inverter will start and keep 230Vac at the secondary output, you will see load on inverter on TFT screen. But in real there is no voltage at the output, because we pull out driver cable for test as you remember. **If there is a problem in this step, please contact with us from whatsapp.**
6. If no problem, and you see load on inverter on TFT screen, please check inverter output voltage and frequency from monitor menu of TFT. Again voltage & frequency is ok, please get a hand multimeter and measure synchron voltage between inverter out (SEC) and bypass (SB). It has to be lower than 20Vac. If you see voltage over than 400Vac, it means inverter is asynchron to bypass.

7. If you have asynchron voltage (>20Vac or >400Vac) between SEC & SB points. Turn off input MCB, wait all energy will be discharged on DC BUS capacitors (you can check multimeter). After all energy in the product discharged, please reverse P1&P2 cable connections from transformer ports like as seen Figure 13 below. And return to first step of this procedure, again measure between SEC & SB points, this time you will see (<20Vac) synchron voltages between inverter out & bypass voltage.

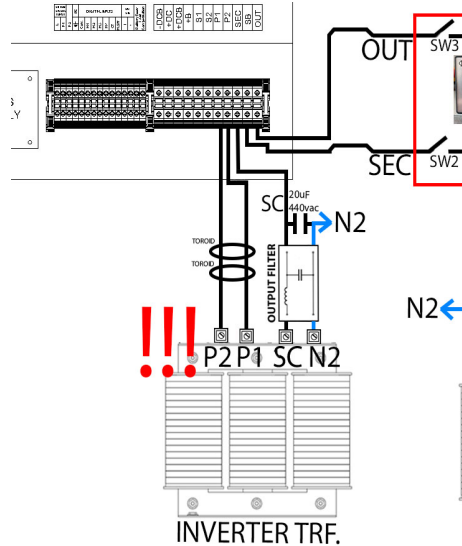

**Figure 13.** Reversing P1 & P2 cable to get true synchronization

8. If you get synchronization, it means your connections are true, turn off inverter from TFT panel, see load on inverter led appears, check inverter voltage from monitor menu as zero volt, now you can connect Figure 12 thyristor driver cable to the driver port. And turn on inverter from TFT panel and see the transfer is ok.

## 9. TCP/IP Converter Connection & Using Procedure

All pess products have a MODBUS MAP list for communication addresses of each reading/writing. This list is given you in "PESS\_ALL\_IN\_ONE\_PC\_HMI Software User Manual\_rev01\_RU". Please use this list to communicate our devices from PC or SCADA. If you prefer to use "PESS\_ALL\_IN\_ONE\_PC\_HMI" to communicate with device, you can download setup file from our webpage.

On the other side, to communicate vis ethernet with TCP/IP protocol, we use a protocol converter that converts RS485 to TCP/IP. This converter should be connected to local modem and get an IP from your modem. You should learn this IP address using converter self HMI. Please apply below steps to learn your converter IP.

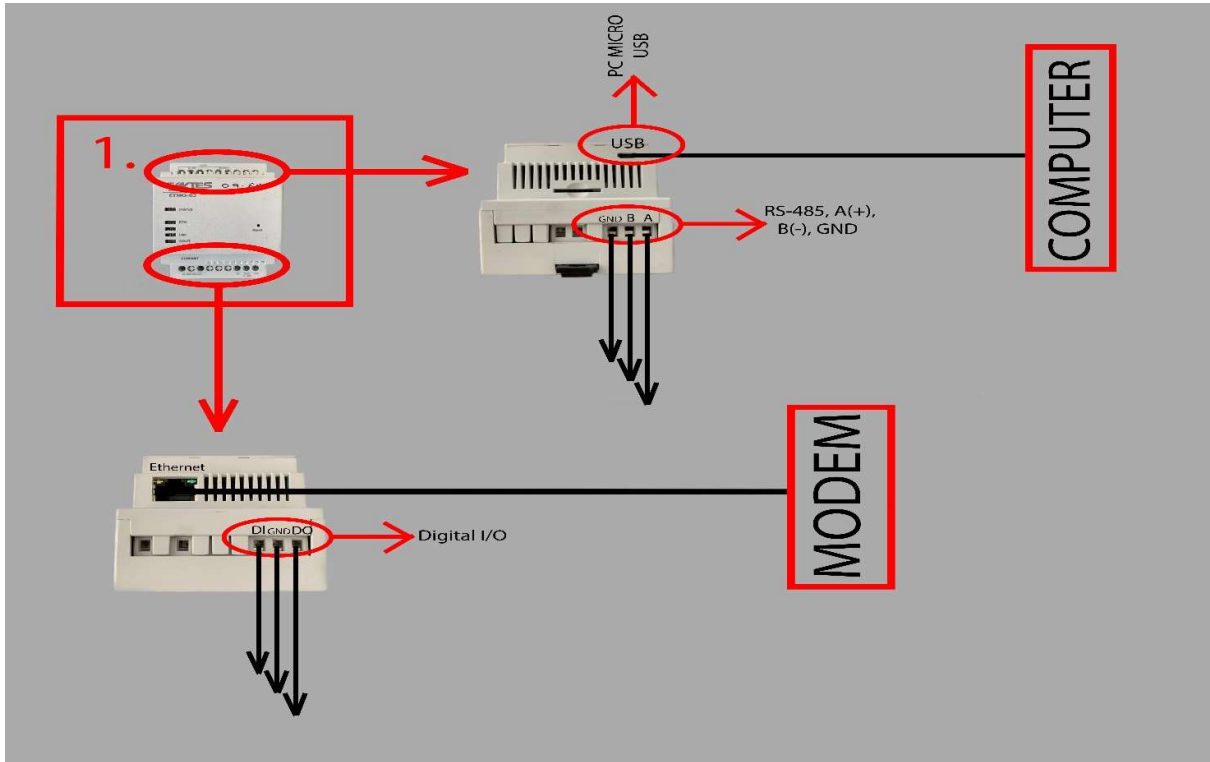
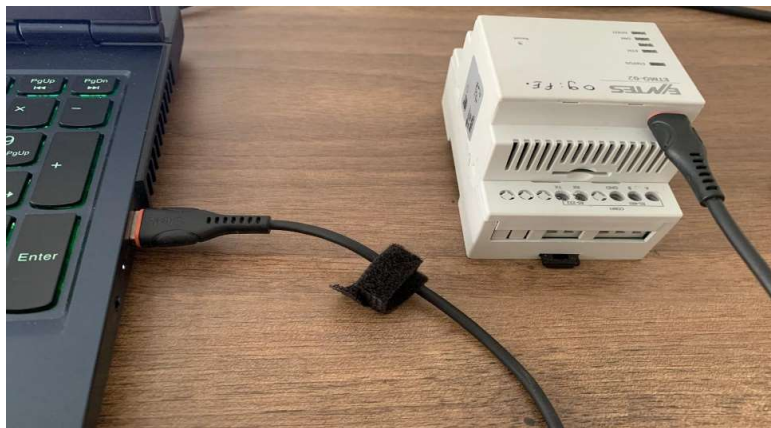

**Figure 14.** TCP / IP converter connection block diagram.

The schematic above shows the connection points. After the necessary connections are made, first we need to access the device's settings via the web interface. There are a few steps to access the web interface.

A desktop program is not used for settings and configuration. A web page that can be opened with web browsers such as Chrome, Firefox, Opera is used to view all settings and settings.

- 1- Firstly, In order to make the device settings from the web interface, it must be connected to the computer with a micro USB cable. In order to access the same interface via Ethernet, the Ethernet IP must be known.



**Figure 15.** Micro Usb Connection Example



- 2- After the device is powered on and connected to the computer via USB, the IP address 192.168.7.1 can be entered into the browser address section, and accessed web page. The last 4 digits of the MAC address your factory default password and this password use for entrance.

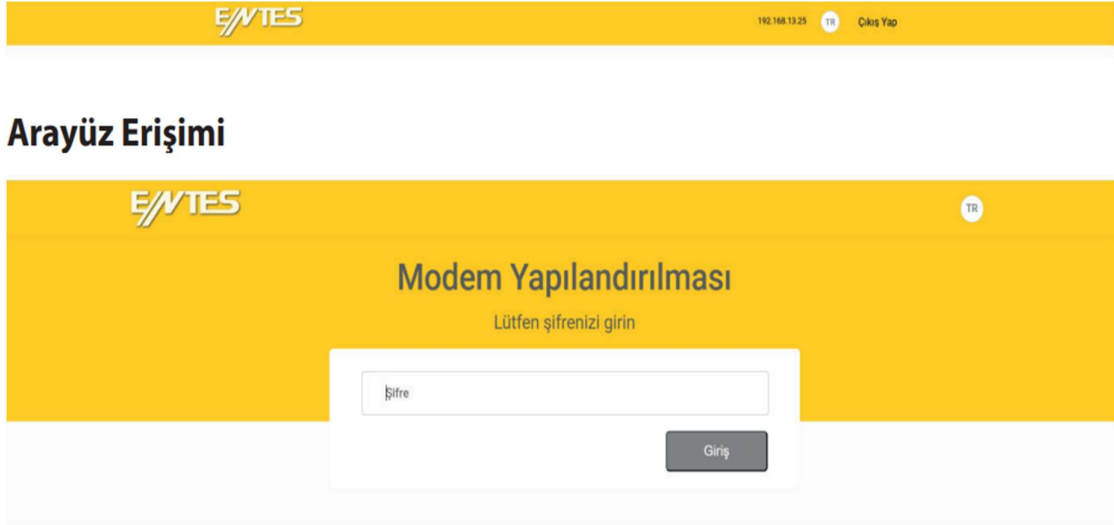

**Figure 16.** Example of the page that opens. On this page, you will enter the last 4 digits of the MAC address in the password section

- 3- Thirdly, when you enter your password you can access the web interface of device. There is menu part top left sight of the page and on this menu part you should click the advanced settings menu (advanced settings menu on the Figure 17, 1. step). After that, you should scroll down and reach the "IP Adress" section (IP Adress section on the Figure 17, 2. Step). Finally, you can see your IP Address. (After reached your IP ADDRESS you can unplug USB.)

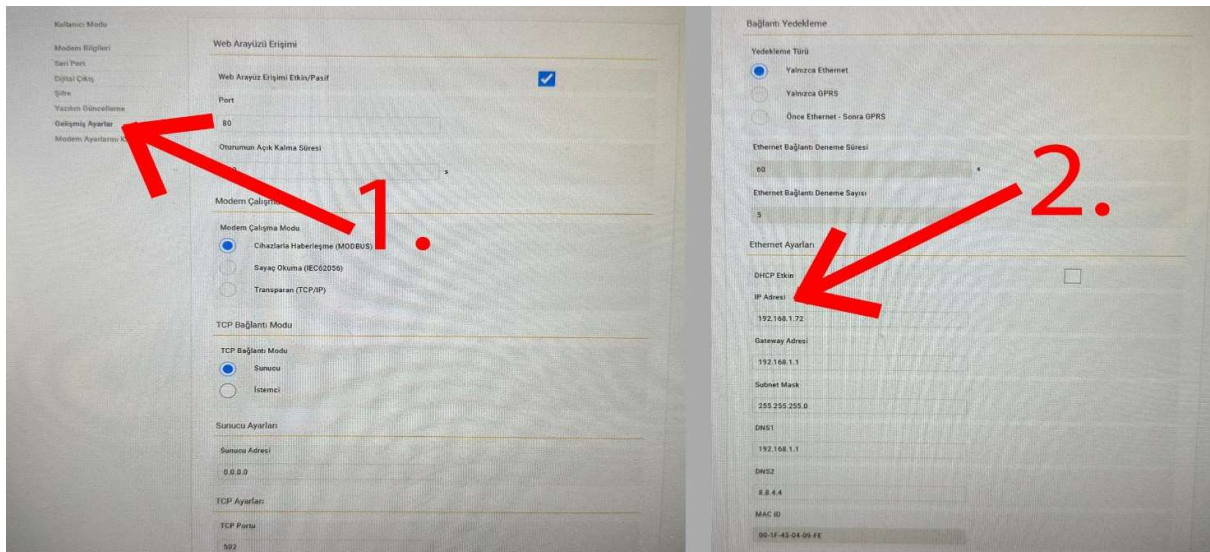

**Figure 17.** Learning local IP address of your TCP/IP converter

4- Finally, you should download the “PESS\_ALL\_IN\_ONE\_PC\_HMI Setup”. After this installation you can reach the HMI, and connect your device the HMI.

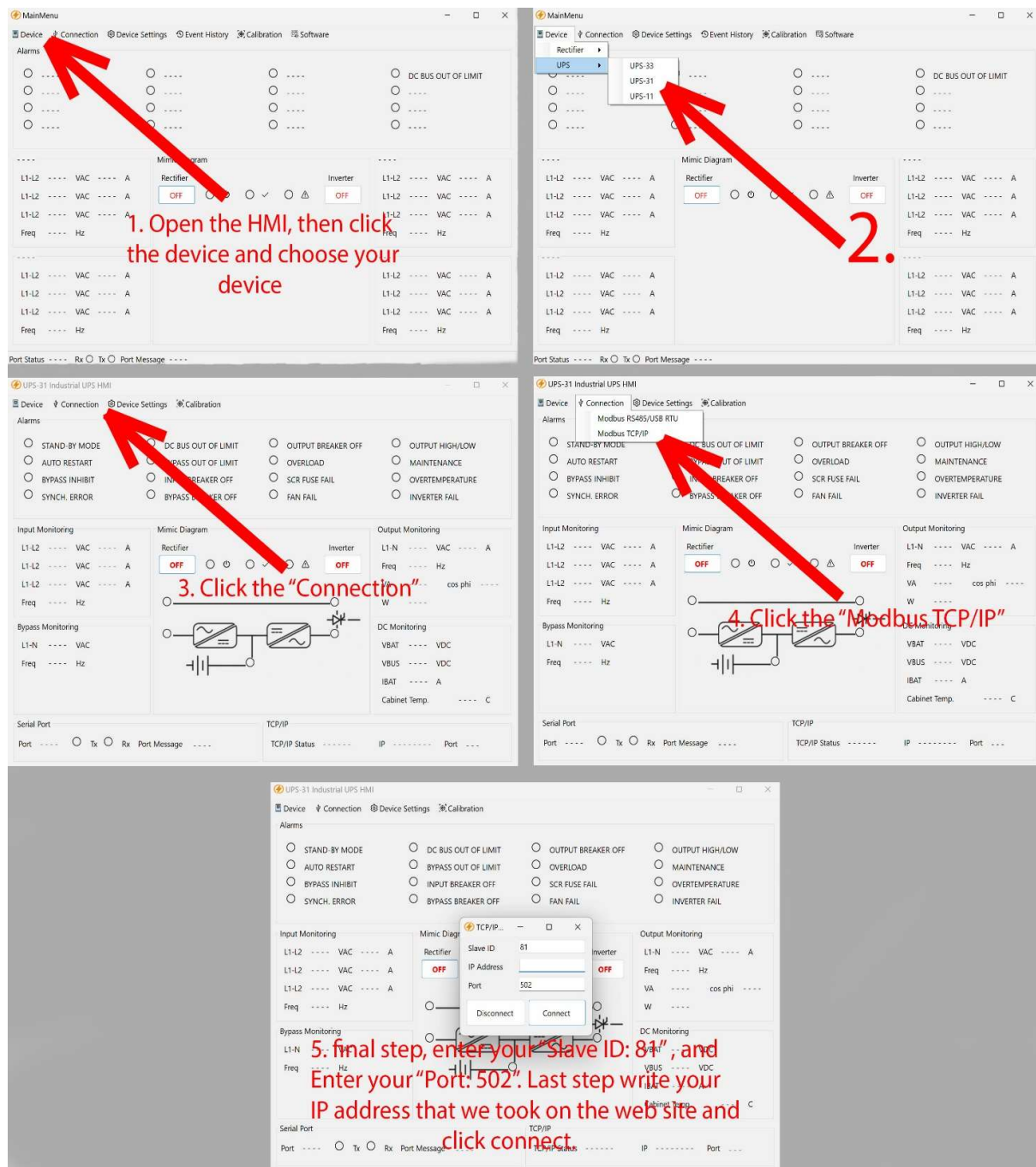

Figure 18. Connecting to device with entering true addresses